

A decorative floral pattern in a light gray color, featuring stylized flowers and scrolling vines, is located in the top right corner of the page.

Classic Design Ceramics

Italian Style Bath

- La Tradizione dello Stile Italiano -

Serie Ottocento

Serie Novecento

Serie Romana

Vasche

by **Italian Style Bath**





Serie **Ottocento**

Quando risalite all'800, fermatevi sui particolari.

*La scelta della qualità, dell'armonia e del vivere.
Linee morbide, sinuose, che ostentano una loro personalità.
Fatti a regola d'arte, secondo la tradizione più antica
con intagli eseguiti a mano e finiture curate. Sono oggetti inconsueti,
parti dell'arredamento che creano spazi e ambienti ancora più piacevoli.
Ogni mattina un viaggio indietro nel tempo,
fino a raggiungere soluzioni lontane dal solito ma così vicine a casa vostra.
La classe, il gusto antico sposato con l'eleganza delle forme.
E' un concetto di bellezza ideale e come tale è perfetto,
astratto e concreto al tempo stesso.
Rendendo armonico anche ciò che era agli opposti*

*When you go back to the nineteenth century,
dwell on the details.*

*The choice of quality, balance and life.
Soft curving lines that flaunt their own personality.
Perfectly made according to the most age-old traditions:
hand carving and careful finishing touches. They are unusual objects,
a part of the decor that creates even more delightful rooms and areas.
A trip back in time every morning, until you stumble on a solution
that is far from ordinary yet so close to home.
Class and bygone taste united with elegant shapes.
This is a concept of ideal beauty and as such it is perfect,
abstract yet concrete,
bringing even diametrical opposites into harmonious balance.*

ottocento

Lavabi



art.870

*Il bacino
contiene la
purezza della
forma ovale,
il design è dolce
e ricco nello stesso
tempo
di complementi
come la spalliera
ed il paraspruzzi.
La colonna è il
prolungamento
naturale di
un'idea bella
e funzionale.*

*The basin
encompasses
a pure oval
shape.
Its design is soft,
nevertheless
at the same time
it is rich in
accessories such
as the backboard
and the splash
plate.
The column is the
natural
extension of a
beautiful
and functional
idea.*

art. 870

• *Lavabo*

Washbasin

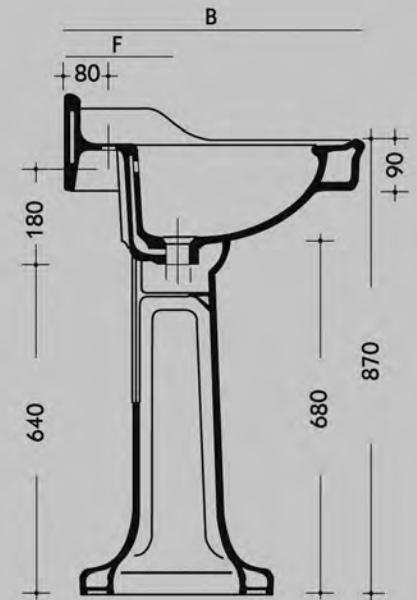
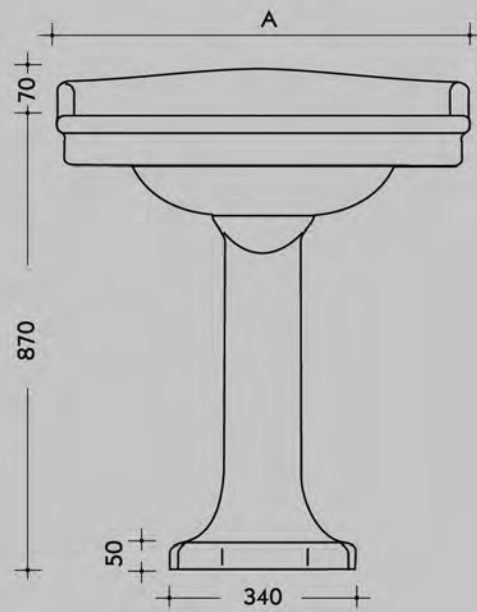

art. 865

• *Lavabo*

Washbasin

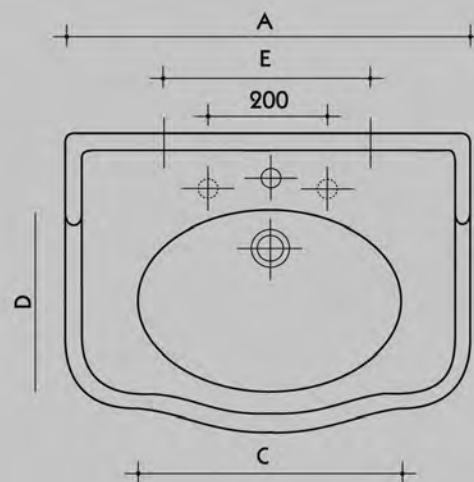

art. 815

• *Colonna per lavabo*

Pedestal

Lavabo	A	B	C	D	E	F
art. 870	720	540	460	320	290	210
art. 865	650	510	430	315	260	200

ottocento



art. 870

*Un delicato
supporto
di bianca
ceramica
sostiene una
forma
ricca di fascino.*

*A delicate
support
of white pottery
sustains
a plenty shape
of glamour.*



Saxabi

art. 870

• *Lavabo*

Wasbbasin

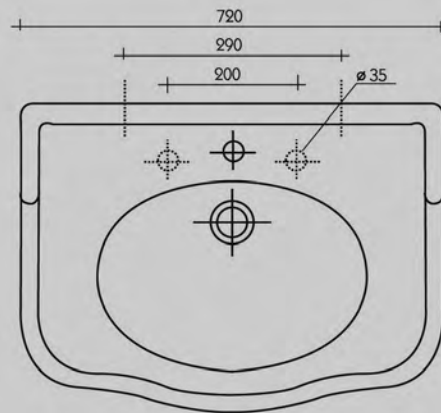

art. 878

• *Coppia mensole*

Brackets

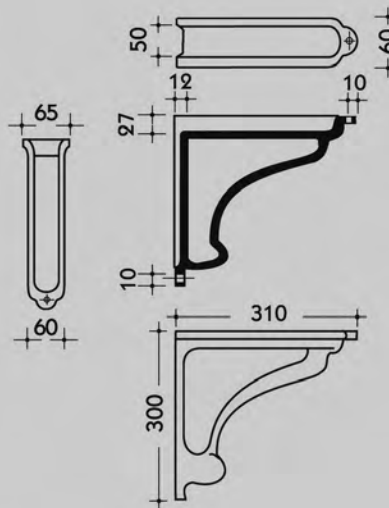

ottocento

art. 870

*Un prezioso
supporto
di lucente
metallo
sostiene la
purezza
di un design
dolce e ricco.*

*A shining
stand
holds up
its soft
design.*

Lavabi

art. 870

• *Lavabo*

Washbasin

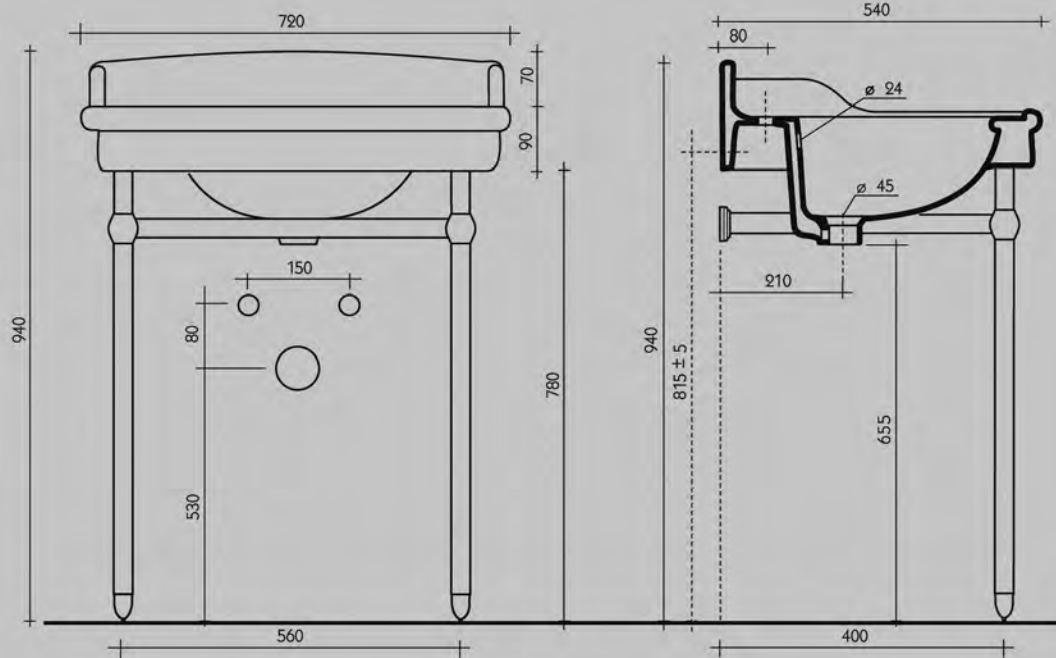

art. 870 bm8

• *Base metallica cromo*

Metal stand chrome

art. 870 bm9

• *Base metallica oro*

Metal stand gold

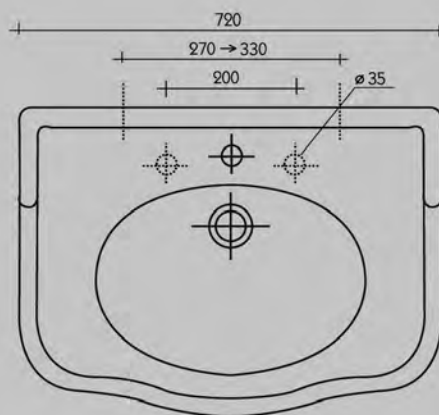

ottocento



art. 899

Un design originale e la comodità di due ampi piani d'appoggio. Le dimensioni d'ingombro sono ottimali per tutte le sale da bagno. L'originalità nasce anche dalle due mensole di porcellana.

Original design and the convenience of two wide counters. The overall size is ideal for any bathroom. The two porcelain shelves also help make it truly unique.

Saxabi

art. 899

• *Lavabo consolle*

Console washbasin

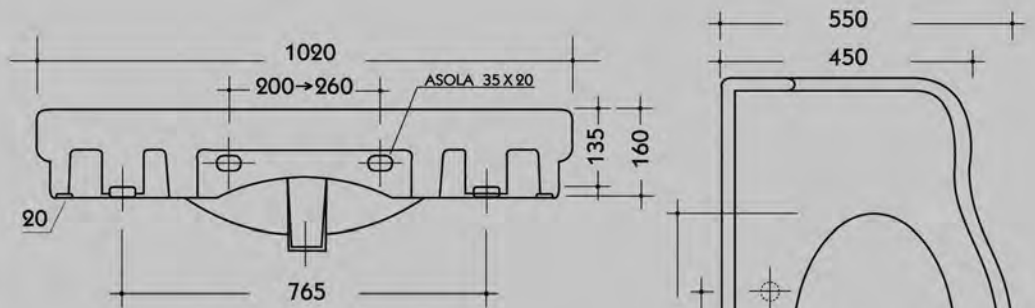

art. 898

• *Coppia mensole
in ceramica*

*Pair of
china brackets*

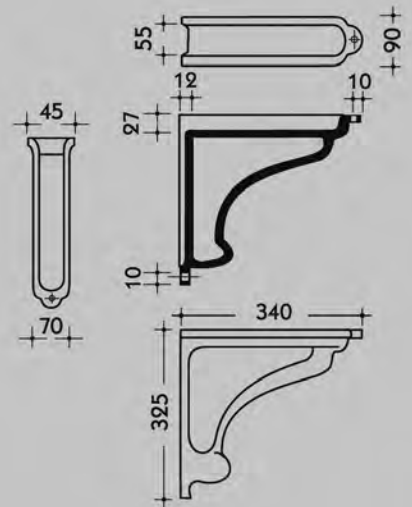
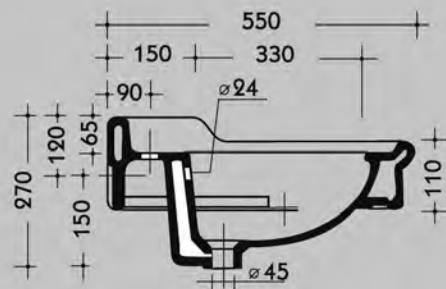
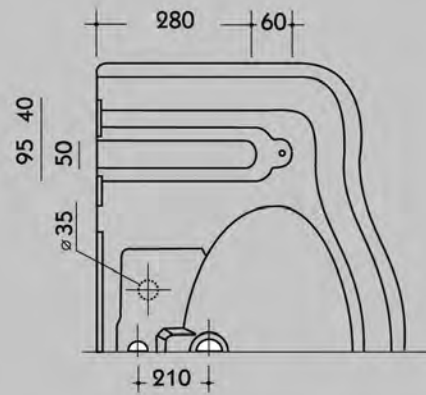

ottocento



art. 899

*Tutta la
comodità
e la classe che
nascono
da un design
unico,
si mettono in
mostra
grazie
all'elegante
supporto
metallico.*

*Comfort and
excellence
of a sole design
shown
by a fashionable
stand.*

Lavabi

art. 899

• *Lavabo*

Consolle basin

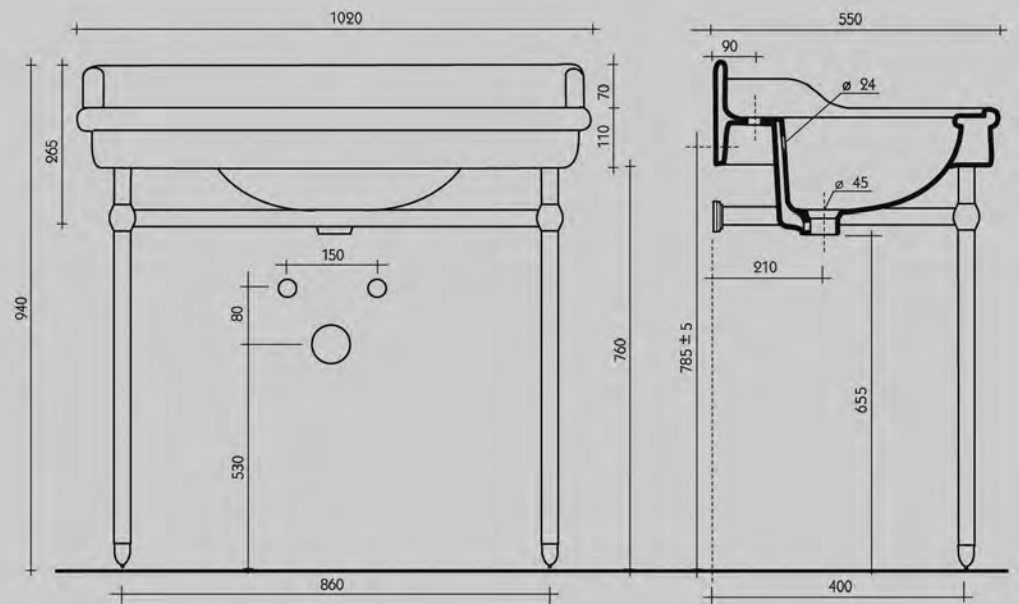

art. 899 bm8

• *Base metallica cromo*

Metal stand chrome

art. 899 bm9

• *Base metallica oro*

Metal stand gold

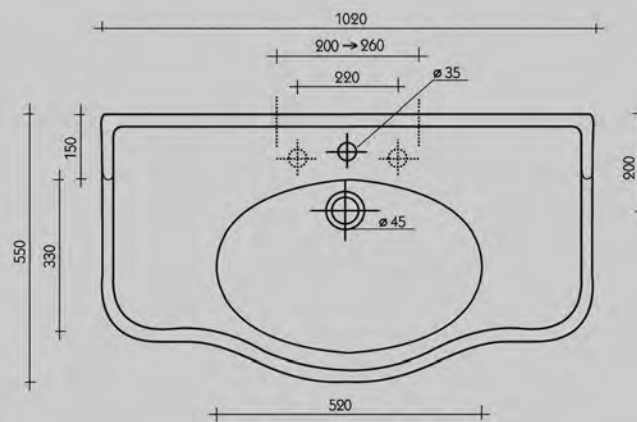

ottocento



art. 830

La grazia ed il candore della porcellana si sposano magistralmente con la tradizionale forma a violino. La base d'appoggio sembra quasi un delicato decoro del pavimento.

The grace and purity of porcelain are skillfully united with the traditional violin shape. The support base almost looks like a delicate floor decoration.

Bidet

art. 830

- Bidet mono tre fori

One - three hole bidet

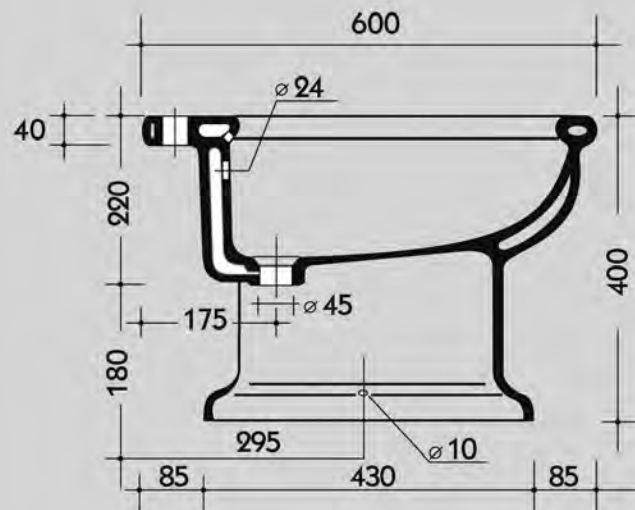

art. 834

- Bidet con foro doccia

Bidet with spray

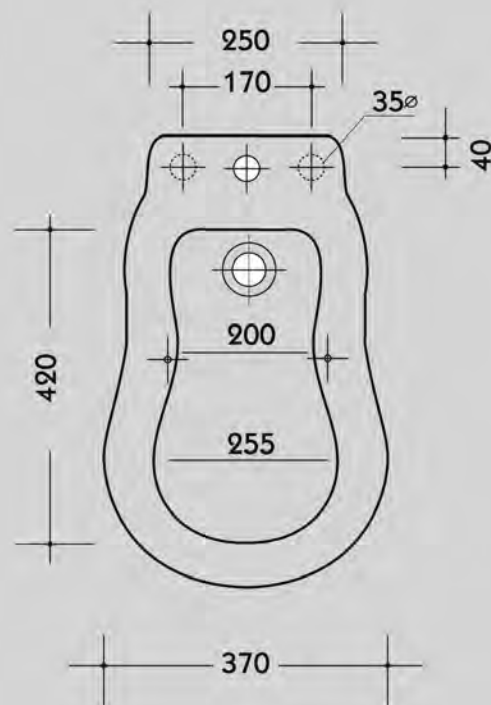

ottocento



Art.820

*Forme morbide,
delicate.
I dettagli creano
un concerto
di risposdenze.
Ciò che inizia
da un'idea di
sobrietà
e leggiadria,
finisce
in diverse
soluzioni.
Qui la cassetta è
alta,
il tubo è esterno.*

*Soft delicate
shapes.
The details here
create a concert
of harmony.
Something that
starts with a
concept
of simplicity
and gracefully
ends
in different
solutions.
The cistern here
is high,
with the pipe
on the outside.*

art. 820

- Vaso con scarico a pavimento

Floor outlet pan

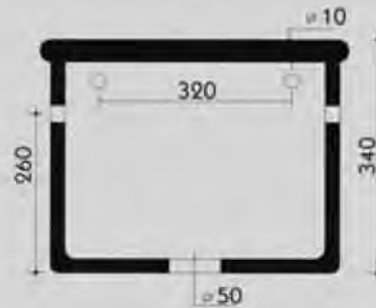

art. 821

- Vaso con scarico a parete

Wall outlet pan

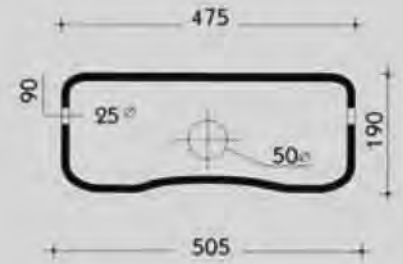

art. 844

- Cassetta alta con coperchio

High level cistern with lid



- Sedile bianco per vaso

White seat and cover

chromo - chrome Art. 828
oro - gold Art. 829

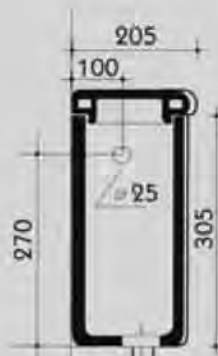

- Sedile noce per vaso

Walnut seat and cover

chromo - chrome Art. 818
oro - gold Art. 819

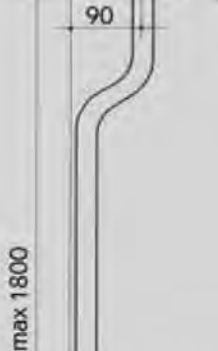

- Batteria cassetta alta con pull e catena

High level cistern mechanism

chromo - chrome Art. 042.8
oro - gold Art. 042.9

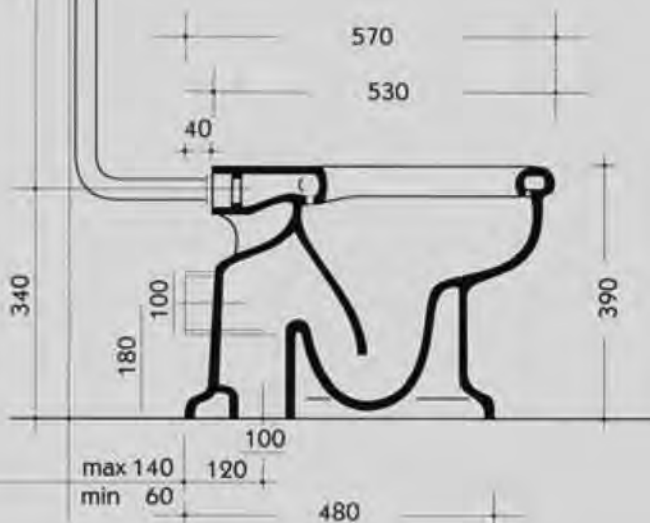

- Tubo esterno per cassetta alta

High level cistern pipe

chromo - chrome Art. 042.8T
oro - gold Art. 042.9T



ottocento



art. 820

*Lo stile viene
declinato secondo
le diverse
esigenze di
estetica
e di funzionalità.
Perché la bellezza
è anche
intelligente.*

*The style is
inflected
according to
different
needs -
appearance
and function.
Because beauty
can also mean
intelligence.*

art. 820

- Vaso con scarico a pavimento

Floor outlet pan

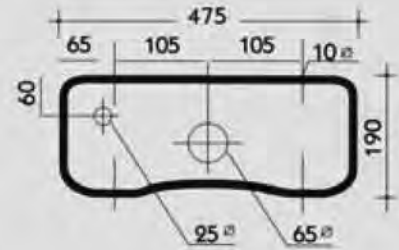
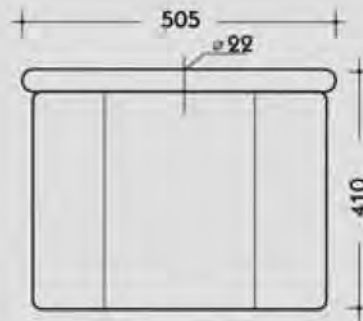

art. 821

- Vaso con scarico a parete

Wall outlet pan

art. 841

- Cassetta zaino

Low level cistern

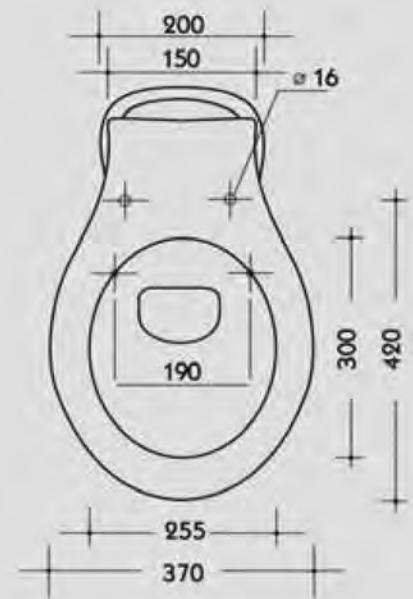

- Sedile bianco per vaso

White seat and cover

chromo - chrome Art. 828
oro - gold Art. 829



- Sedile noce per vaso

Walnut seat and cover

chromo - chrome Art. 818
oro - gold Art. 819

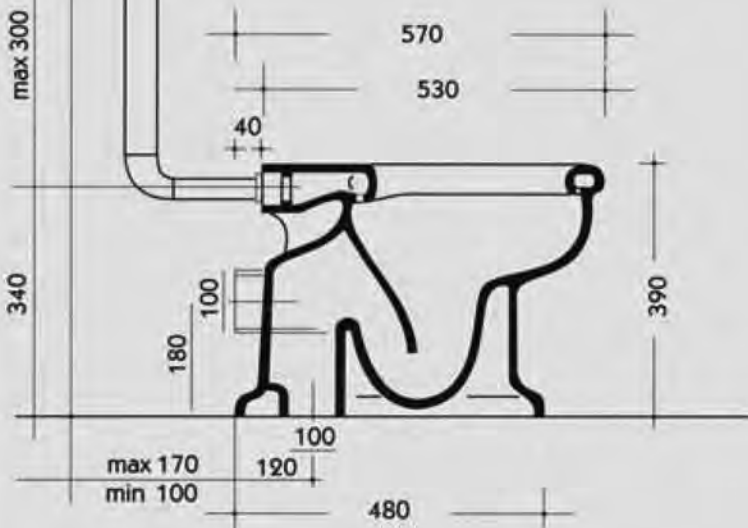

- Batteria cassetta zaino con curva

Low level mechanism with pipe

chromo - chrome Art. 041.8
oro - gold Art. 041.9

ottocento



art. 824

*Un altro
punto di vista.
La versatilità di
un'idea desta
sempre
ammirazione.
La funzionalità
si trasforma
a piacimento.*

*Another
viewpoint.
The versatility
of an idea also
stirs up
admiration.
Functionality
can be
transformed
at will.*

art. 824

• Vaso
monoblocco S/Terra

Floor outlet
close coupled pan

art. 825

• Vaso monoblocco
P/Parete

Wall outlet
close coupled pan

art. 840

• Cassetta
monoblocco

Close coupled cistern

• Sedile bianco per vaso
White seat and cover

cromo - chrome Art. 828
oro - gold Art. 829

• Sedile noce per vaso
walnut seat and cover

cromo - chrome Art. 818
oro - gold Art. 819

• Batteria monoblocco

Close coupled mechanism

cromo - chrome Art. 040.8
oro - gold Art. 040.9

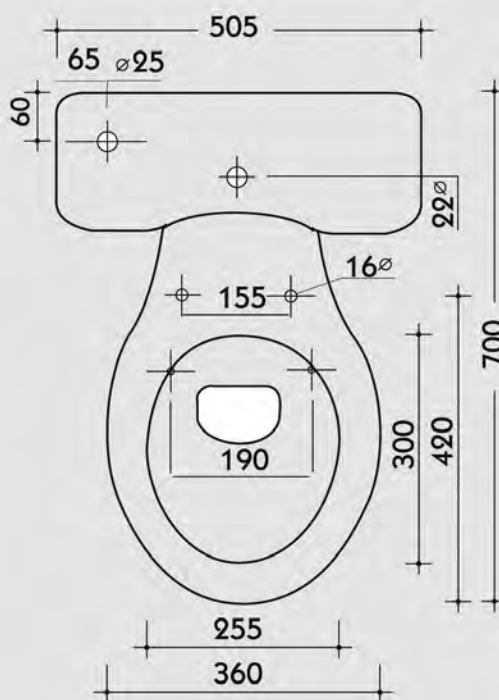
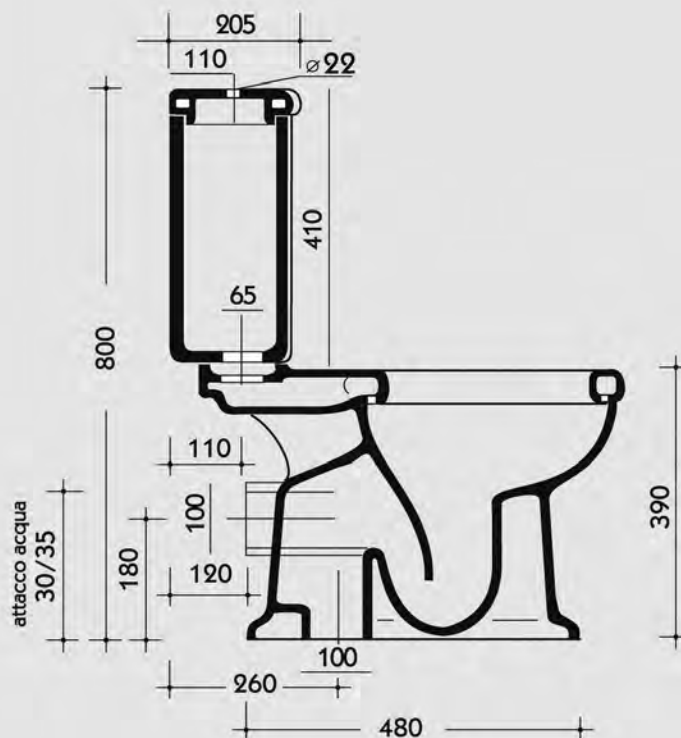

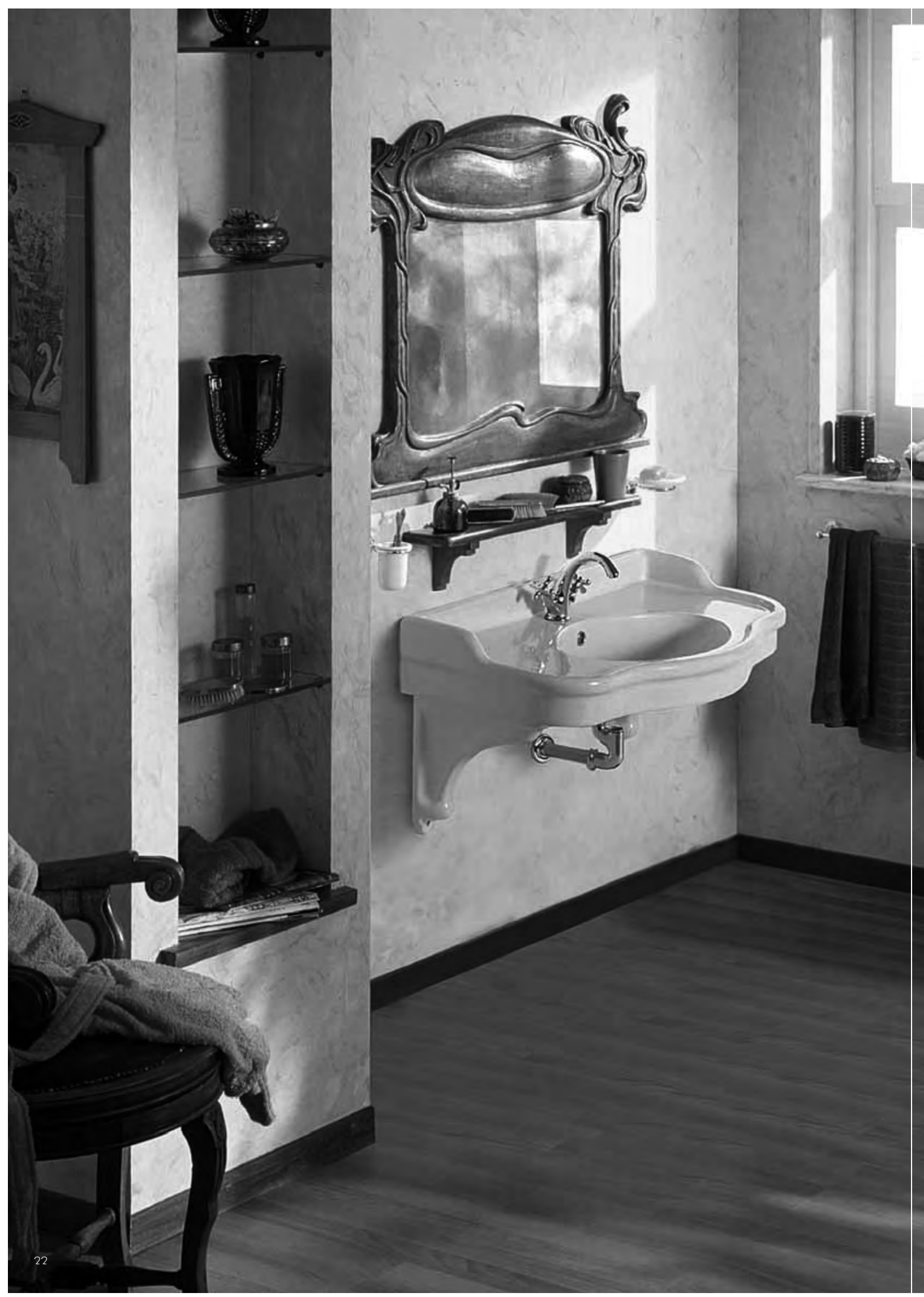



ottocento



art.836

*L'eleganza
prende il volo.
Qui ogni
particolare,
ogni curva,
sfida la forza
di gravità
per ridare
all'ambiente
luce e spazio.*

*The grace
and purity
of porcelain
are skillfully
united with the
traditional
violin shape.
The support base
almost looks like
a delicate
floor decoration.*

Bidet

art. 836

- *Bidet sospeso monoforo erogazione esterna*

Wall hung bidet for monoblock mixer

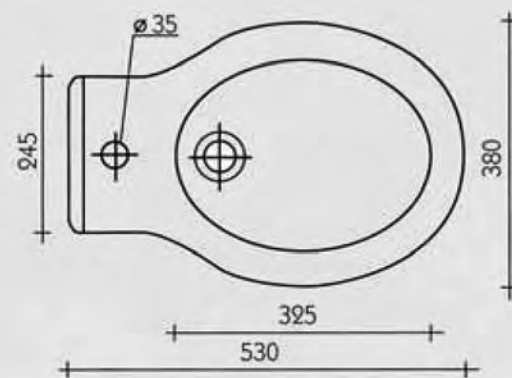
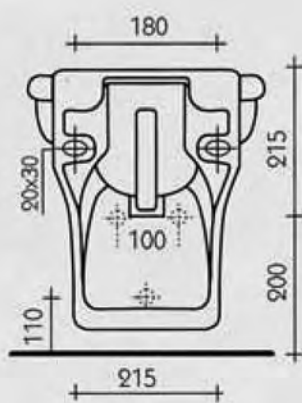
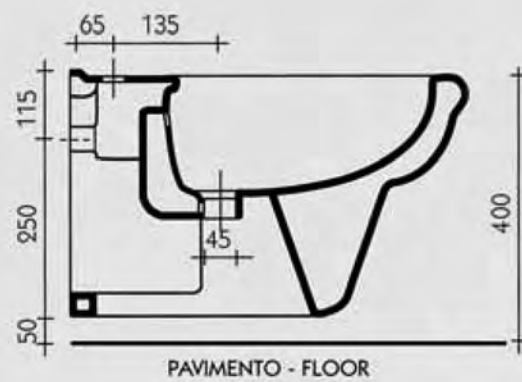

ottocento



art. 826

*La porcellana
bianca e pura,
resta sospesa
leggera nello
spazio.*

*La funzionalità
non è più
astratta
ma reale*

*The pure and
white porcelain
are skillfully
united with the
traditional
violin shape.*

*The support base
almost looks like
a delicate
floor decoration.*

Casi

art. 826

• *Vaso sospeso*

Wall hung pan

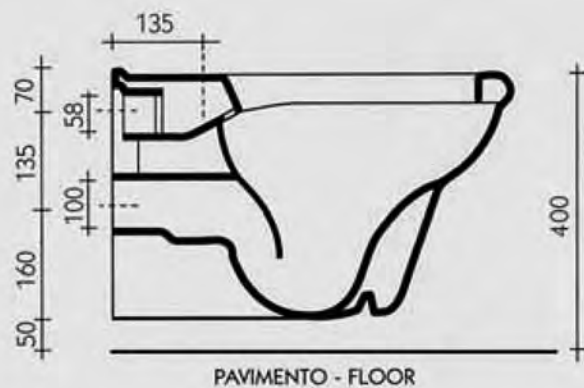

• *Sedile bianco per vaso*
White seat and cover

chromo - chrome Art. 828
oro - gold Art. 829

• *Sedile noce per vaso*
walnut seat and cover

chromo - chrome Art. 818
oro - gold Art. 819

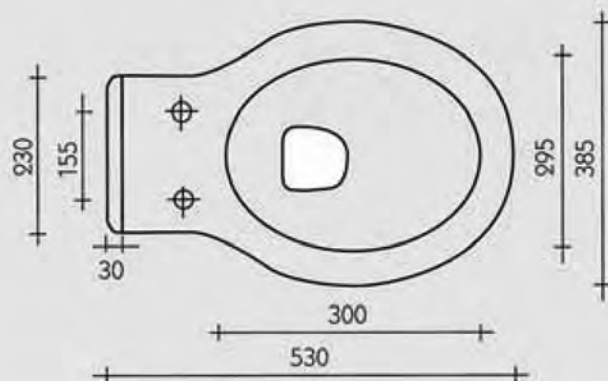
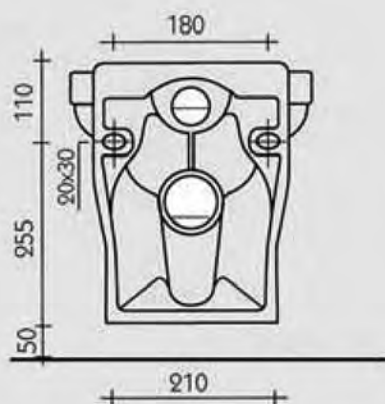



art.2702

*Ritorno
alle forme classiche.
Secondo
dimensioni classiche.
L'optimum
per un'installazione
sotto un piano
d'arredamento.*

*A return
to classic shapes
according to classic
dimensions. Ideal
for installation under
a decorative counter.*



art.2590

*Sobrietà e funzionalità
per un'installazione
sopra il piano
d'appoggio.
La rubinetteria
è perfettamente
a suo agio.*

*Dignity
and function
for an installation
on top of the counter.
The taps and fittings
are right at home here.*

art. 2703

• *Lavabo sottopiano*

Recessed basin

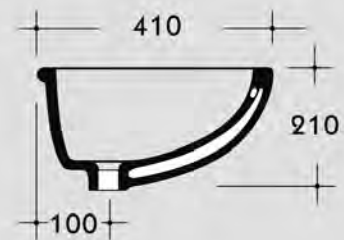
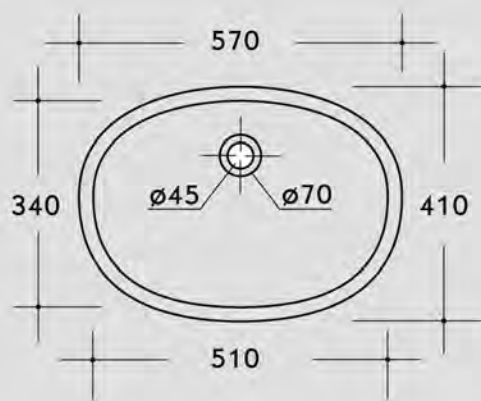

art. 2590

• *Lavabo sopra piano*

Built-in basin

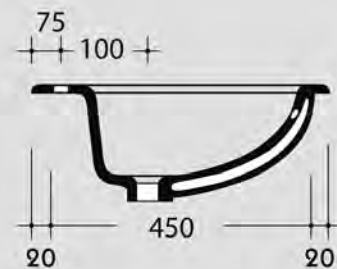
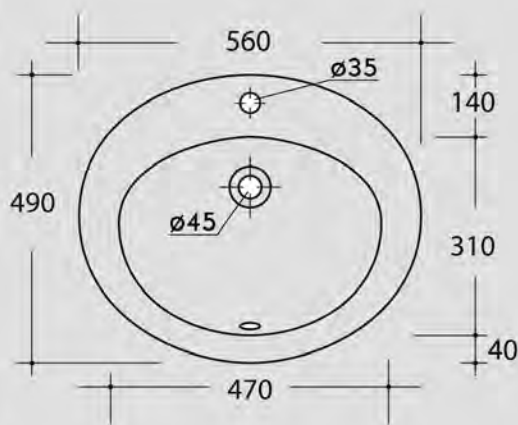



art. 2704

*L'ovale, la forma pura.
Permette
mille accostamenti,
sposa gli arredamenti.
Rimanendo orgogliosa
e indipendente.*

*The oval: pure form.
It goes with thousands
of things and brings
the decor together,
amount of space proudly
and independently.*



art. 2580

*Seguire il gusto,
lasciandosi sedurre
da un certo fascino.
Ogni nota segue
l'idea di armonia.
Di forme e contenuti.*

*Follow your own taste,
letting yourself
get beguiled
by a certain charm.
Each note follows
the idea of harmony,
form and content.*

art. 2704

• *Lavabo sottosopra ovale*

Oval built-in basin

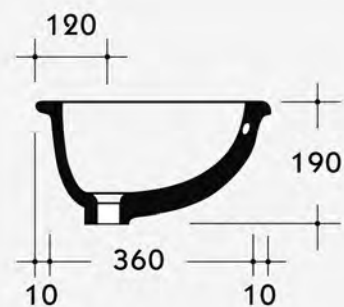
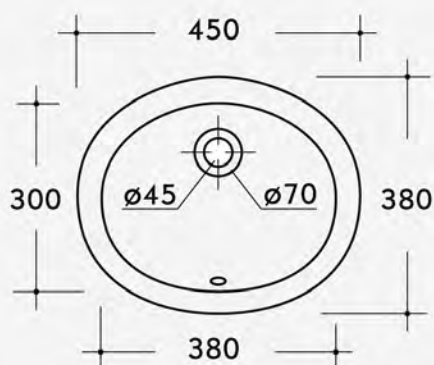

art. 2580

• *Lavabo soprapiano piatto*

Built-in basin

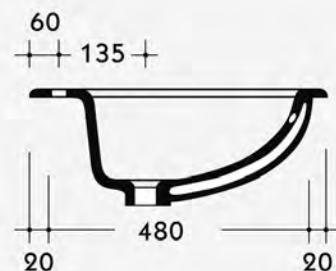
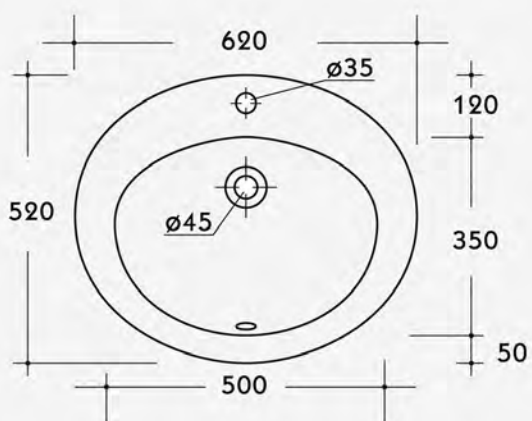





Serie Novecento

Eleganza e seduzione di atmosfera primo novecento.

Il lavabo si presenta in forme squadrate e slanciate.

Il design è elegante, suggestivo.

Le linee rigorose e dinamiche valorizzano il desiderio di classico e di tradizione di chi ama il calore del bagno.

Nell'estetica si riflette la funzionalità, come ad esempio la comodità del paraspruzzi.

Gestione dello spazio, realizzazione del gusto, soluzioni di classe.

Nel gran numero di modelli l'unico standard è nella ricerca della qualità.

Altissima.

Dall'uso di materiali naturali, alla preziosa artigianalità della lavorazione, alla vetrificazione della porcellana:

tutto è in linea con una qualità reale e garantita.

Elegance and seduction with a turn-of-the-century air.

The basin has a squared-off soaring shape.

The design is charming and elegant. The simple and dynamic lines bring out the desire for classics and for tradition felt by those who love the warmth of the bathroom.

Function as part of esthetics: in the splash plates, for example.

Managing space, embodying taste, offering elegant solutions.

The search for quality marks the sole standard throughout the great number of models: the very best.

From the use of natural materials to precious hand-crafted workmanship to vitrification of the porcelain: everything is done in keeping with true and guaranteed quality.

novecento

Lavabi



art. 970

*Lo stile presenta
le sue linee di
condotta: pure,
rigorose,
attraenti.*

*L'importanza
dei particolari
fa bella mostra di
sé:*

*il paraspruzzi
è frontale,
il bacino è ampio
e accogliente.*

*Style presents
its lines of
conduct:
pure, stark,
attractive.*

*The importance
of details
makes a good
showing
of itself:*

*the splash plate
faces front
and the basin
is broad and
inviting.*

art. 970

- *Lavabo quadro*

Washbasin square

Lavabo	A	B	C	D	E	F	G	H	L	M	N	R	S
art. 970	690	560	480	340	240	80	92	870	190	270	145	60	105
art. 965	650	500	470	305	230	70	82	860	190	245	130	60	95
art. 958	590	450	430	270	215	66	75	840	185	290	120	60	85

art. 965

- *Lavabo quadro*

Washbasin square

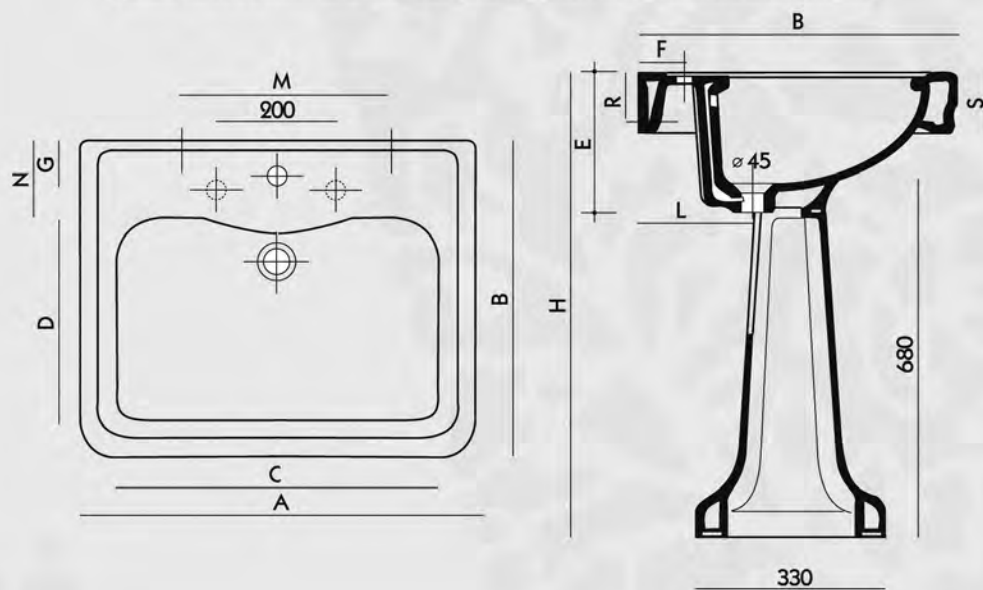

art. 958

- *Lavabo quadro*

Washbasin square

art. 915

- *Colonna per lavabo*

Pedestal

novecento



art. 970

*L'espressione
massima della
purezza,
del rigore,
dell'attrazione,
ha finalmente
trovato
il suo trono.*

*Clearness
and rigour at last
with their
throne.*

Lavabi

art. 970

• *Lavabo*

Washbasin

art. 970 bm8

• *Base metallica cromo*

Metal stand chrome

art. 970 bm9

• *Base metallica oro*

Metal stand gold

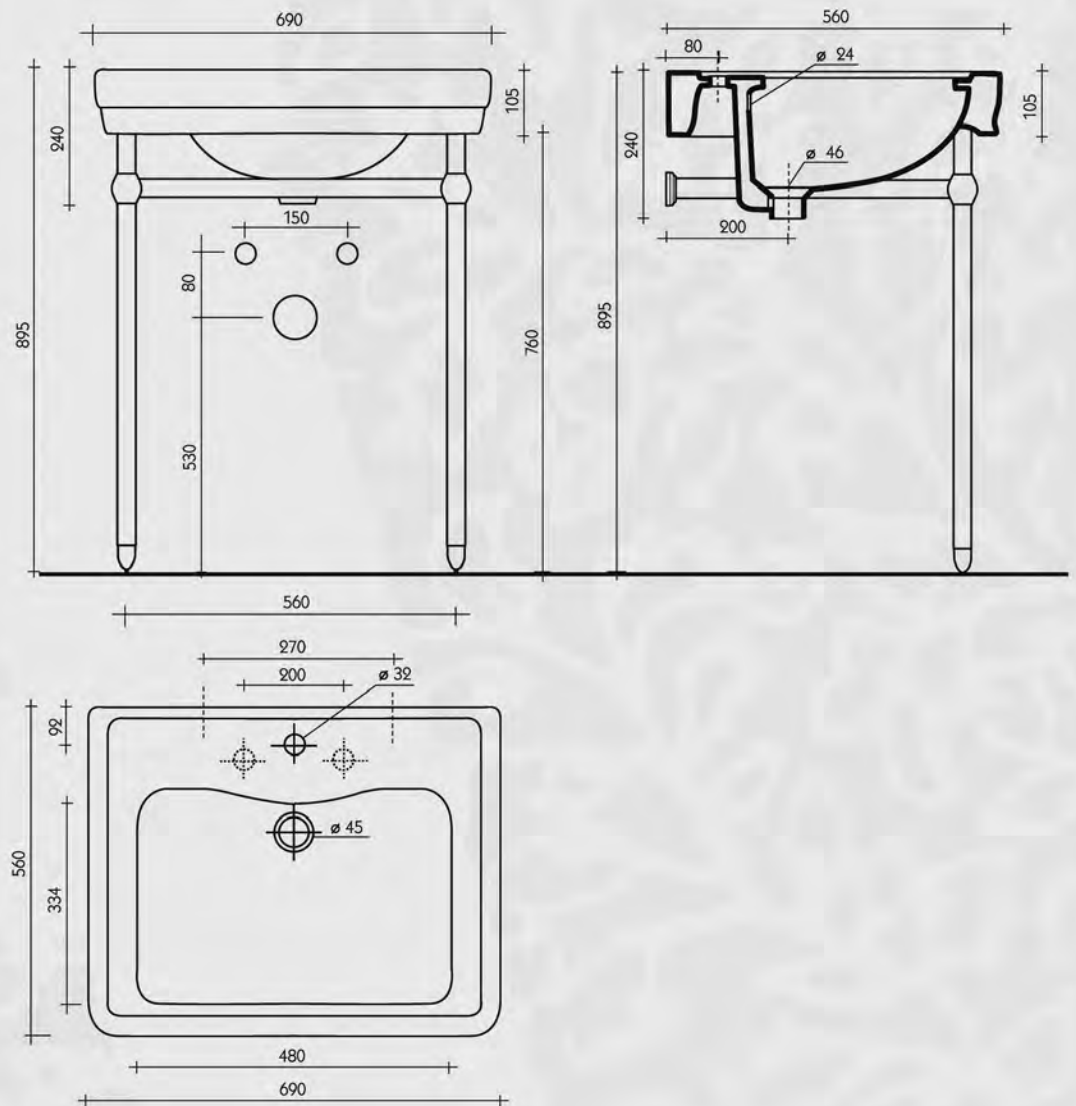

• *Base metallica di prossima realizzazione anche per lavabo 965 e 958*
Metal stand in short term available also for basin 965 and 958

novecento



art. 969

*L'eleganza
segue un'altra
strada,
ma la classe è
sempre
la via da seguire.
Qui la linea
frontale curva
permette
numerose
applicazioni
in spazi meno
ampi.*

*Elegance takes
a different turn,
but class is
always
the right path to
follow.
Here, the front
line
curves to allow
numerous
applications in a
limited amount
of space.*

Lavabi

art. 969

- *Lavabo semitondo*

Wasbbasin round

art. 959

- *Lavabo semitondo*

Wasbbasin round

art. 915

- *Colonna per lavabo*

Pedestal

Lavabo	A	B	C	D	E	F	G	H	L	M	N	R	S
art. 969	680	565	550	350	240	75	85	850	200	260	150	70	105
art. 959	590	480	470	300	210	60	65	830	170	250	120	60	85

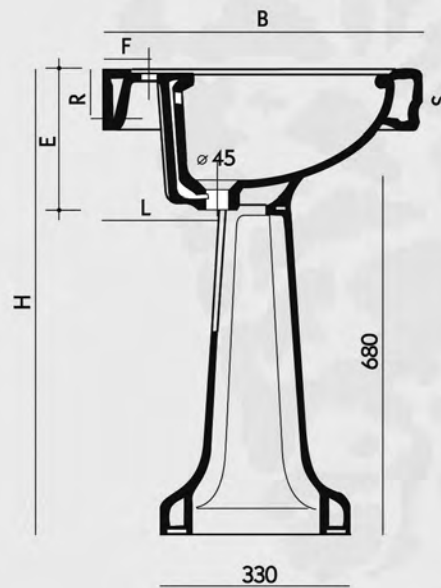
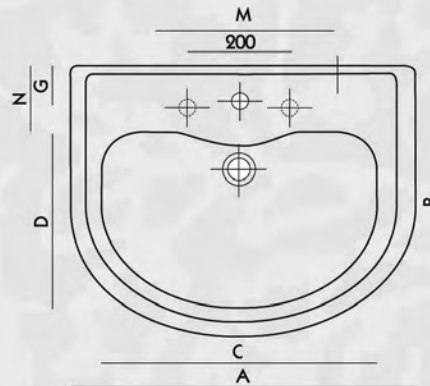



art. 964

*Sofisticata
leggerezza.
La scelta
rimane sospesa.
Ma superbamente
inserita
nell'arredamento.
Al minore
ingombro
si accompagna
l'unicità del
carattere.*

*Sophisticated
lightness.
Choice is left
hanging, but is
magnificently
included in the
decor.
Compact size
is accompanied
with unique
character.*

art. 964

• *Lavabo semincasso*

Semi - inset basin

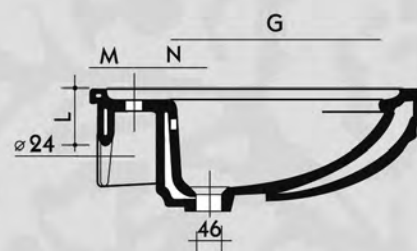
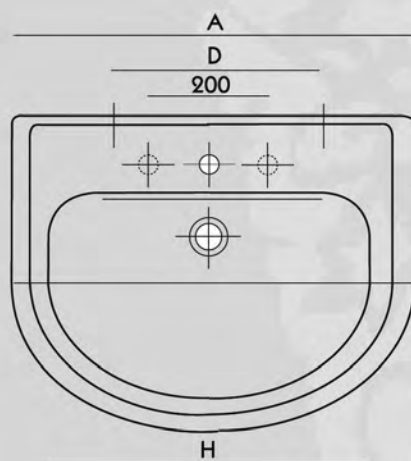

art. 956

• *Lavabo semincasso*

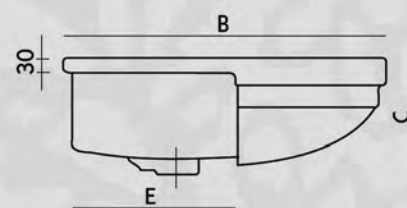
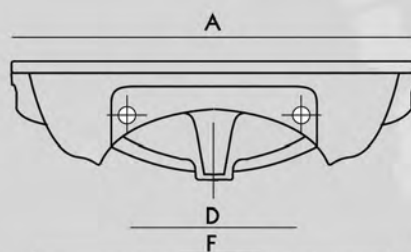

Lavabo	A	B	C	D	E	F	G	H	L	M	N	P
art. 964	650	525	200	290	260	595	330	550	85	75	135	210
art. 956	580	435	210	210	200	530	290	490	70	65	90	155

novecento

Bidet



art.930

*Le forme seguono
concetti di design
e di comodità.*

*La sapiente
esperienza
dell'artigiano
si riconosce
nei particolari.*

*E nell'aver
mantenuto la
caratteristica
brida.*

*Shape follows
the concepts of
design
and comfort.*

*The knowing
experience
of the craftsman
can be recognized
in the details.*

*And in having
kept
the characteristic
rim.*

art. 930

- Bidet mono tre fori

One - three holes bidet

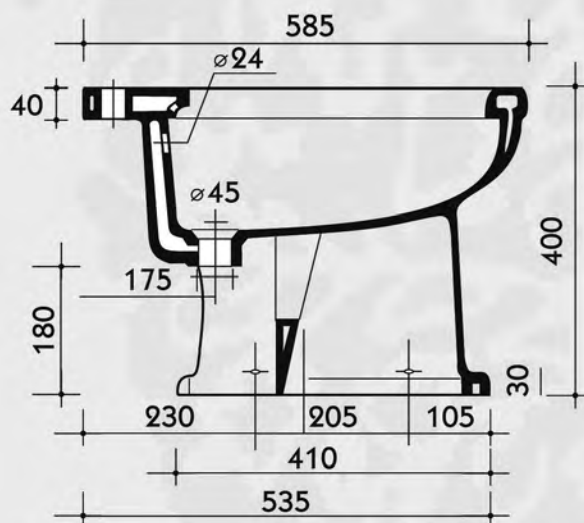

art. 934

- Bidet con foro per doccia

Bidet with spray

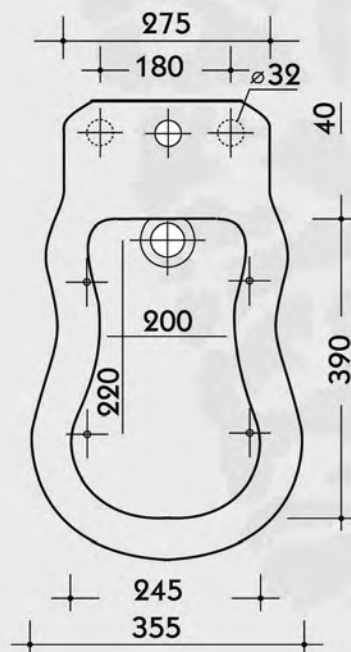



art.920

Figure squadrate, linee che portano dritte dritte ad atmosfere di altri tempi. E torna di moda la cassetta alta, anche con il comando a catenella ed il tubo esterno.

Squared-off figures, lines that bring you straight into the atmosphere of another age. The high cistern is back in fashion, together with the chain pull and the pipe on the outside.

art. 920

- Vaso con scarico a pavimento

Floor outlet pan

art. 921

- Vaso con scarico a parete

Wall outlet pan

art. 944

- Cassetta alta con coperchio

High level cistern with lid

- Sedile bianco per vaso

White seat and cover

cromo - chrome Art. 928
oro - gold Art. 929

- Sedile noce per vaso

Walnut seat and cover

cromo - chrome Art. 918
oro - gold Art. 919

- Batteria cassetta alta con pull e catena

High level cistern mechanism

cromo - chrome Art. 042.8
oro - gold Art. 042.9

- Tubo esterno per cassetta alta

High level cistern pipe

cromo - chrome Art. 042.8T
oro - gold Art. 042.9T

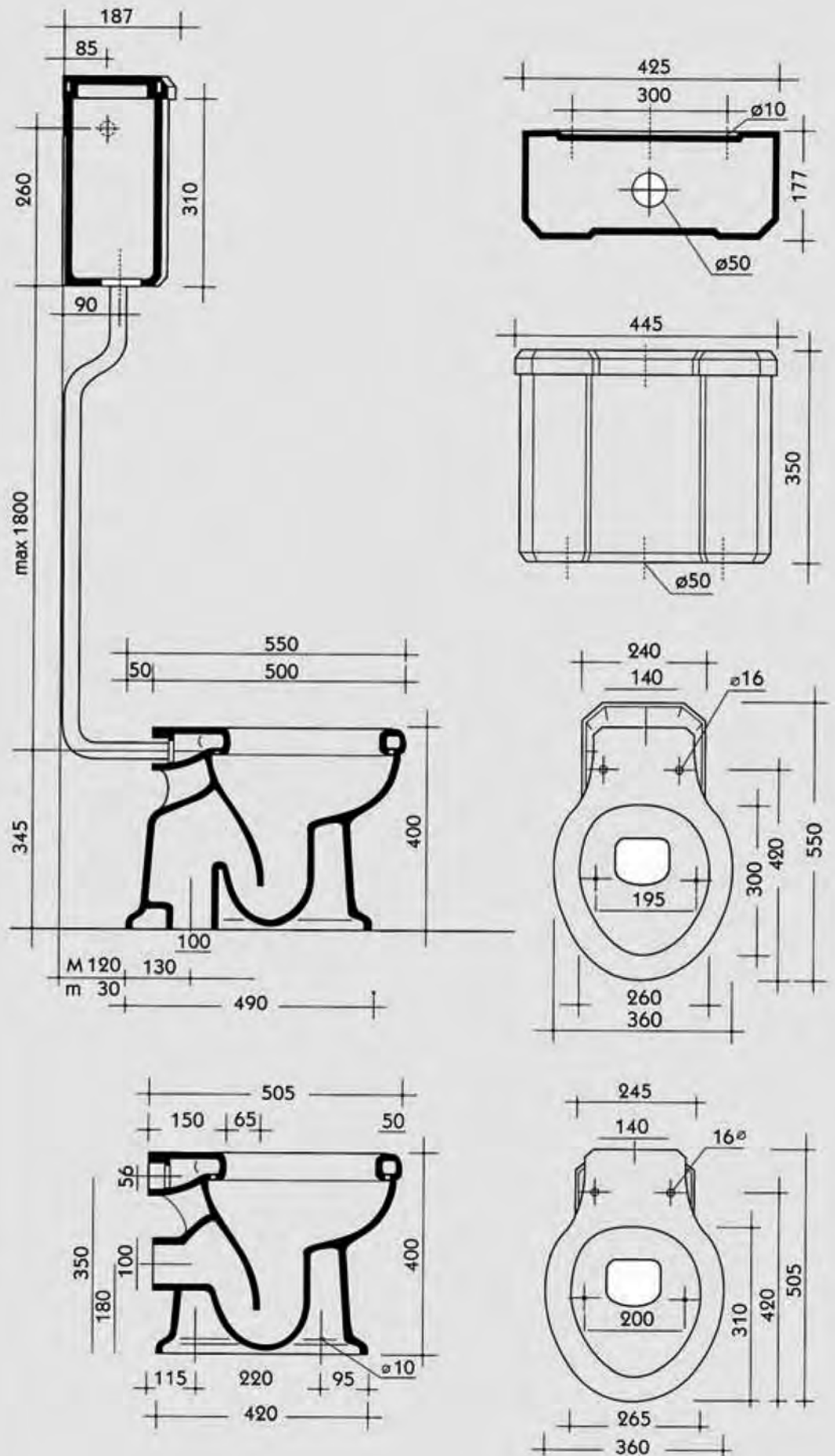

novecento

Oasi

art. 920

A ciascuno il suo.

Le scelte sono sempre di gusto, anche se dettate da ragioni pratiche. Qui la soluzione è vincente in alcune zone geografiche più sensibili a problemi di scarico.

E richiama subito lo stile di quei tempi.

To each his own.

Choices also reflect taste, even if they are dictated by practical reasons.

This is a winning solution in some of the geographical areas that are more sensitive to drainage problems.

And it immediately brings the style of those times to mind.



art. 920

- Vaso con scarico a pavimento

Floor outlet pan

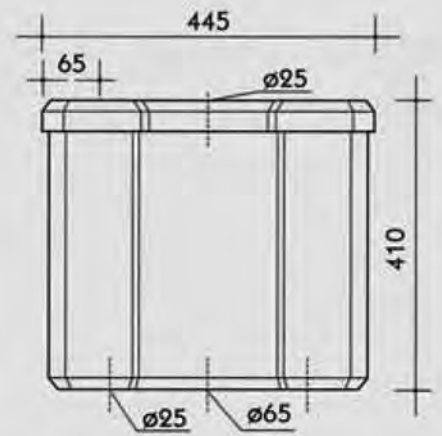

art. 921

- Vaso con scarico a parete

Wall outlet pan

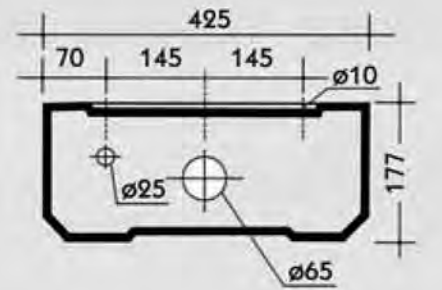
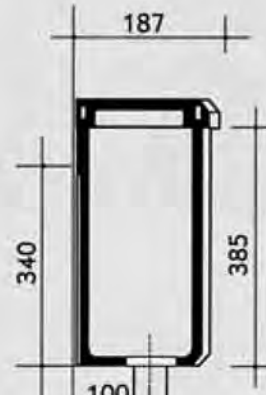

art. 941

- Cassetta zaino

Low level cistern

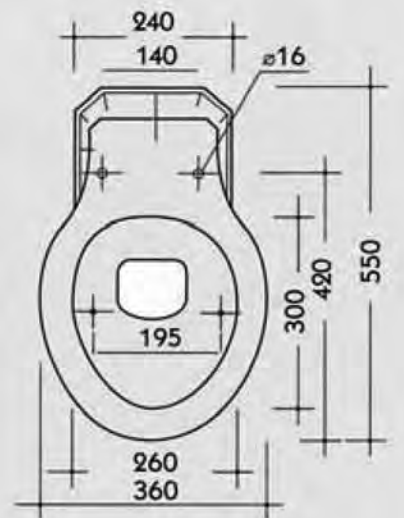
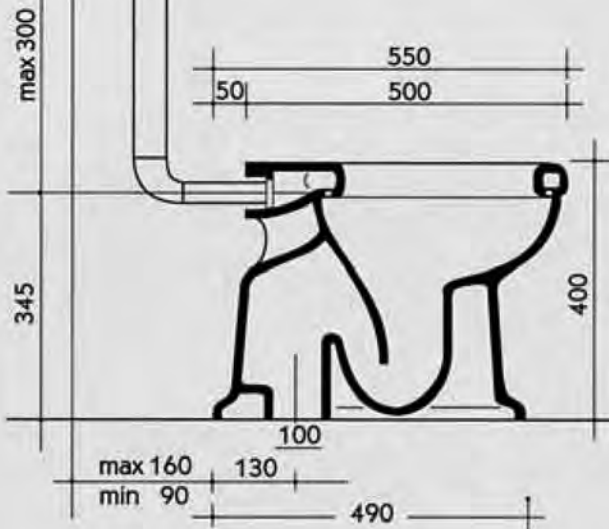

- Sedile bianco per vaso

White seat and cover

chromo - chrome Art. 928
oro - gold Art. 929

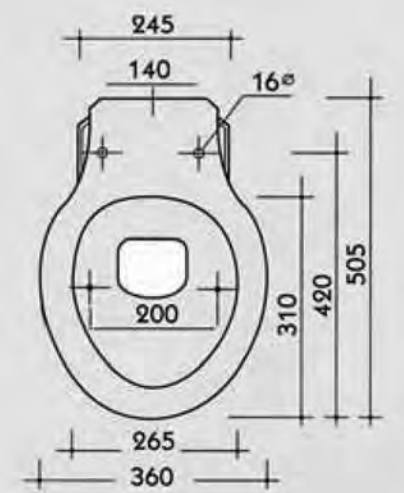
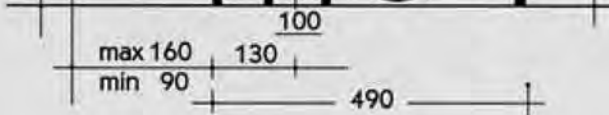

- Sedile noce per vaso

Walnut seat and cover

chromo - chrome Art. 918
oro - gold Art. 919

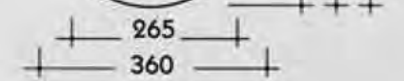
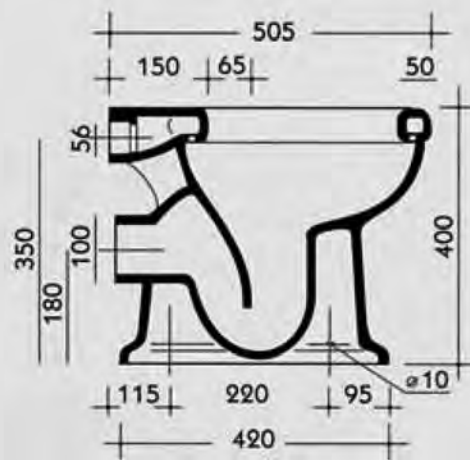

- Batteria cassetta zaino con curva

Low level mechanism with pipe

chromo - chrome Art. 041.8
oro - gold Art. 041.9

novecento



art. 924

*L'evoluzione della
specie.*

*Una soluzione
che semplifica
l'installazione
e semplifica la
vita.*

*La qualità
è sempre alta.
Unica e rara.*

*The evolution
of the species.
A solution
that simplifies
installation
and will simplify
your life.*

*Quality
is also foremost.
Rare and
unique.*

Oasi

novecento

Casi

50

art. 922

*In accordo con
l'ultima
evoluzione
tecnica,
mantenendo la
rigorosità del
design classico
italiano con
questo prodotto si
ottimizzano spazi
e igienicità
dell'ambiente.*

*In perfect
armony with
the last technical
evolution,
keeping the
precision of the
Italian classic
design, with
this new product
spaces and
cleanliness are
optimized*



art. 922

Vaso filo parete
filo pavimento

Back to wall pan (BTW)

- Sedile bianco per vaso
White seat and cover

cromo - chrome Art. 928
oro - gold Art. 929

- Sedile noce per vaso
walnut seat and cover

cromo - chrome Art. 918
oro - gold Art. 919

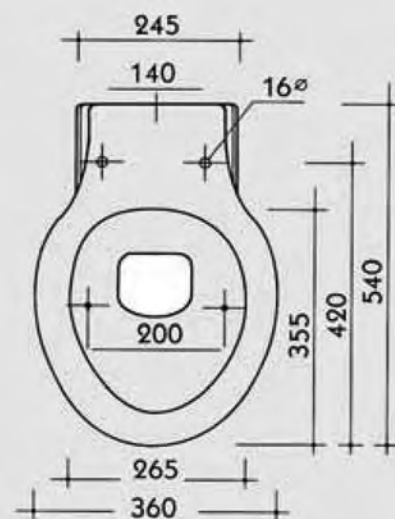
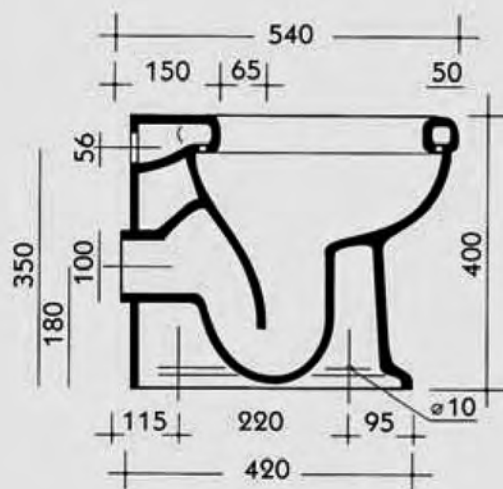

novecento

Bidet



art.936

*L'esperienza
e la maestria
artigianale
si riconoscono
anche
in questo
modello: unico.*

*Our experience
and excellent
workmanship
make this a
unique product.*

novecento

Oasi

54



art.926

*Funzionalità,
estetica,
pulizia.
Aspettative che
vengono
rispettate
completamente.
Segno
inconfondibile
di uno stile
unico.*

*Functional,
elegant, very
clean.
Fully meets your
highest
expectation.
Unmistakable
and unique style.*

art. 926

• *Vaso sospeso*

Hanging pan

• *Sedile bianco per vaso*
White seat and cover
cromo - chrome Art. 908
oro - gold Art. 909

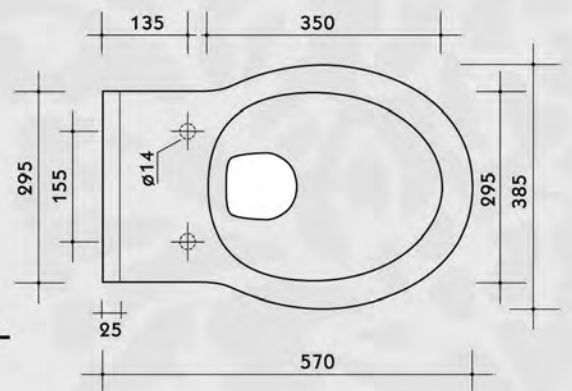
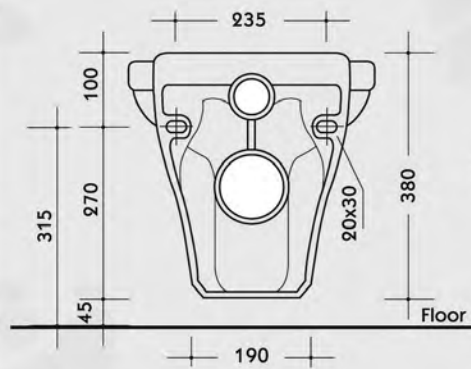
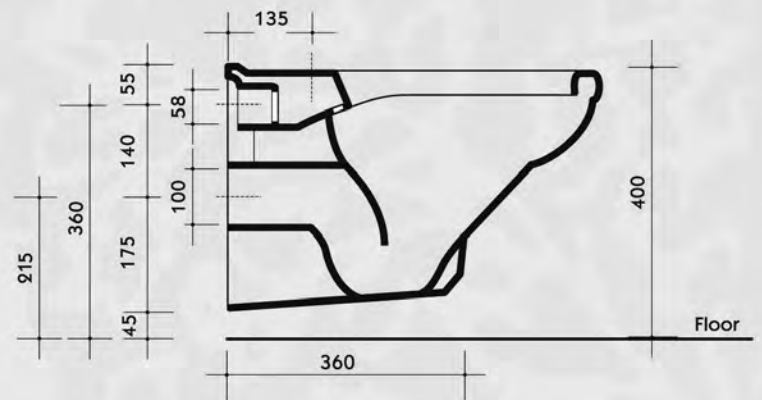





Serie Romana

L'armonia, indispensabile atmosfera del luogo di culto del corpo e dello spirito.

Una collezione che nasce da una tradizione antica, dove la qualità si combina perfettamente con il design.

Sin dai tempi dell'antica Roma destava grande interesse l'arte del creare armonia attraverso le forme, i colori e la gestione degli spazi.

Per raggiungere questo obiettivo, Archiade ha studiato un design dolce come quello che appartiene alle morbide linee ovali e raffinato come le rigorose linee squadrate.

Il risultato è la collezione Romana, dove eleganza e praticità, novità e tradizione si fondono insieme in una ricerca estetica che va al di là d'ogni precedente standard.

The place of worship of body and mind requires the essential ingredient, harmony.

A collection that arises from an ancient tradition, where quality perfectly combines with design.

Since ancient Roman times the art of creating harmony through shapes, colours and management of spaces was of great interest.

With this objective in mind, Archiade has created a gentle design as gentle as those belonging to oval lines and as refined as the rigorous lines of the square.

The result is the Romana collection, where elegance and practicality, innovation and tradition blend together in an aesthetic research that goes beyond any previous standard.

romana



art. 790

Una linea invidiabile, elegante e utile, con la spalliera, i paraspruzzi e le mensoline laterali.

L'esaltazione dello spazio nell'ambiente, ottenuto, grazie all'utilizzo di gambe di metallo cromato, come prosecuzione ideale del bacino a terra.

An enviable line, elegant and useful, with the back, the water barrear and the lateral shelves.

The exaltation of space in the environment, obtained, thanks to the utilization of chrome-plated metal supports, an ideal continuation of the ground basin.

Lavabi

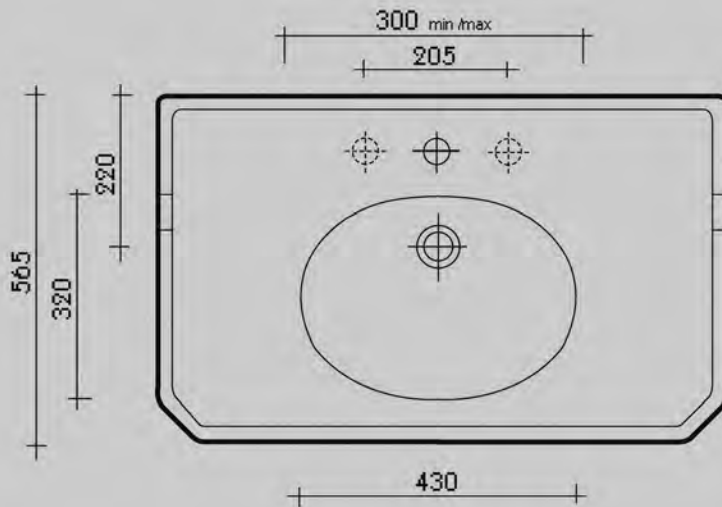

art. 790

- *Lavabo consolle*

Console washbasin

art. 790 bm8

- *Base metallica cromo*

Metal stand chrome

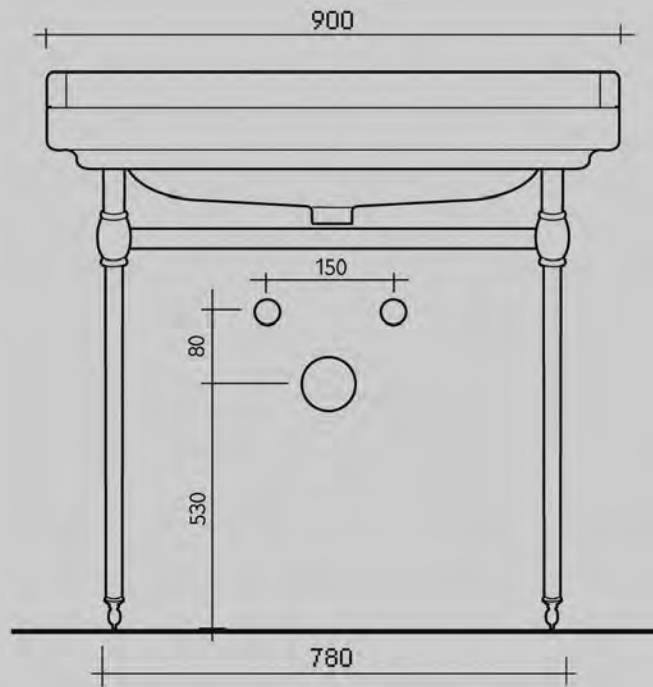

art. 790 bm9

- *Base metallica oro*

Metal stand gold

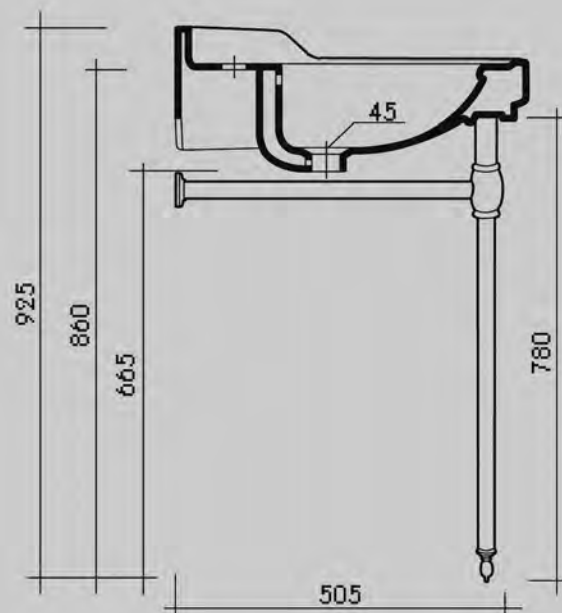

romana



art. 765

Dal perfetto matrimonio tra forme tonde e squadrate nasce un modello romantico, le cui linee slanciate sono ammorbidite da movimenti curvi. Contenere le forme come lo spazio, per dare libertà d'utilizzo.

A romantic model, arises from a perfect matrimony between round and squared shapes of which the straight lines are softened by curving movements. Containing shapes and space, giving freedom of utilization.

Lavabi

art. 765

• Lavabo

Wasbbasin

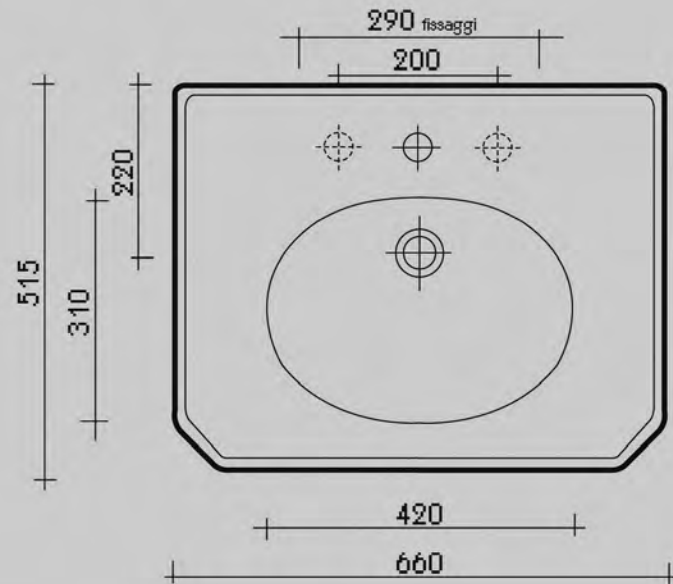

art. 715

• Colonna

Pedestal

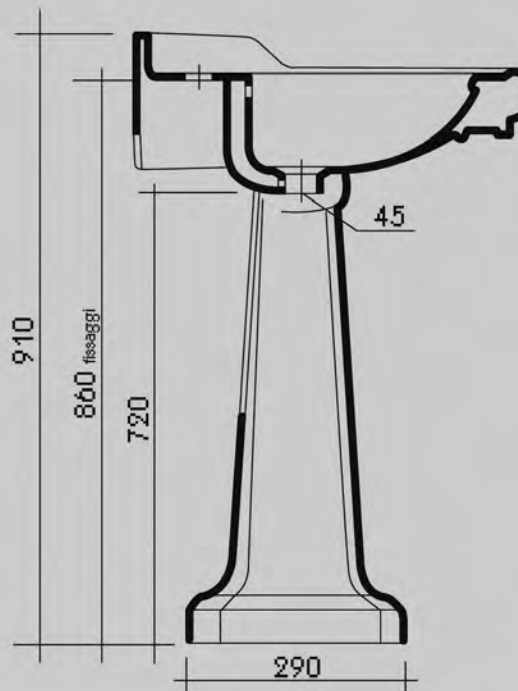

romana



art. 750

*La leggerezza
prende forma
e porta nel bagno
l'agilità delle
linee,
la sveltezza
come atmosfera.
Rinnovarsi,
cambiare
prospettive
provare nuove
direzioni
solo così si
raggiunge
l'armonia.*

*The lightness
takes form
and carries
in the bathroom
the agility of
lines,
the promptness
like
as an
atmosphere.
Renewing,
changing
prospect, trying
new directions:
only in this way
one's can attain
the harmony.*

Lavabi

art. 750

• *Lavabo*

Waschbasin

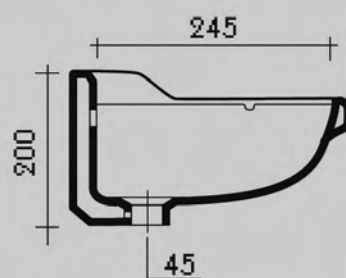
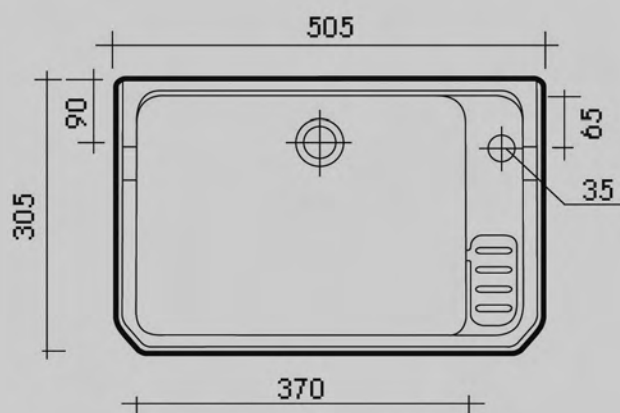

romana

Bidet



art. 730

*La finissima
porcellana
non è il solo
elemento
che contribuisce
a rendere unico
questo modello.
Imprescindibili,
infatti,
sono la comodità
e il design.
Un'integrazione
meravigliosa
è il risultato.*

*The fine
porcelain
is not the only
element that
contributes
in making
this model
unique.
In fact, comfort
and design,
cannot be set
aside.
The result
is a wonderful
integration.*

art. 730

- *Bidet mono tre fori*

One - three holes bidet

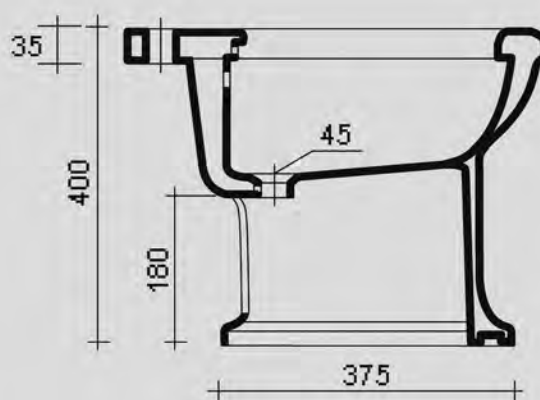
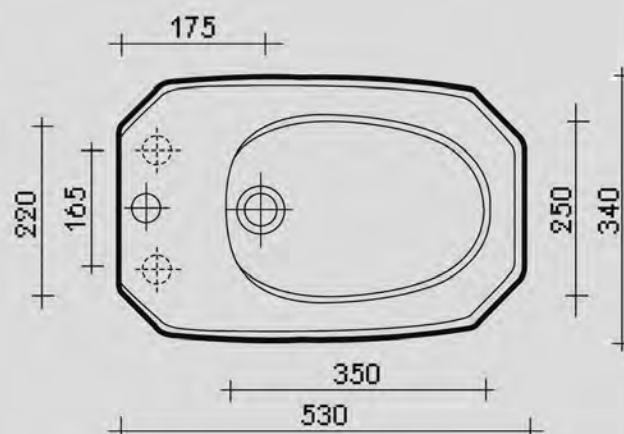

romana



art. 720

L'ascesa verso apici di stile consente al tubo di essere esterno ed al comando a catenella di accompagnarlo. La cassetta in alto poi, chiude l'armonia dell'intera struttura.

The highest of style allows the pipe to be external and to be accompanied by the external chain. The cistern then, completes the harmony of the whole structure.

Casi

art. 720

- Vaso con scarico a pavimento

Floor outlet pan

art. 721

- Vaso con scarico a parete

Wall outlet pan

art. 944

- Cassetta alta con coperchio

High level cistern with lid

- Sedile bianco per vaso

White seat and cover

cromo - chrome Art. 728
oro - gold Art. 729

- Sedile noce per vaso

Walnut seat and cover

cromo - chrome Art. 718
oro - gold Art. 719

- Batteria cassetta alta con pull e catena

High level cistern mechanism

cromo - chrome Art. 042.8
oro - gold Art. 042.9

- Tubo esterno per cassetta alta

High level cistern pipe

cromo - chrome Art. 042.8T
oro - gold Art. 042.9T

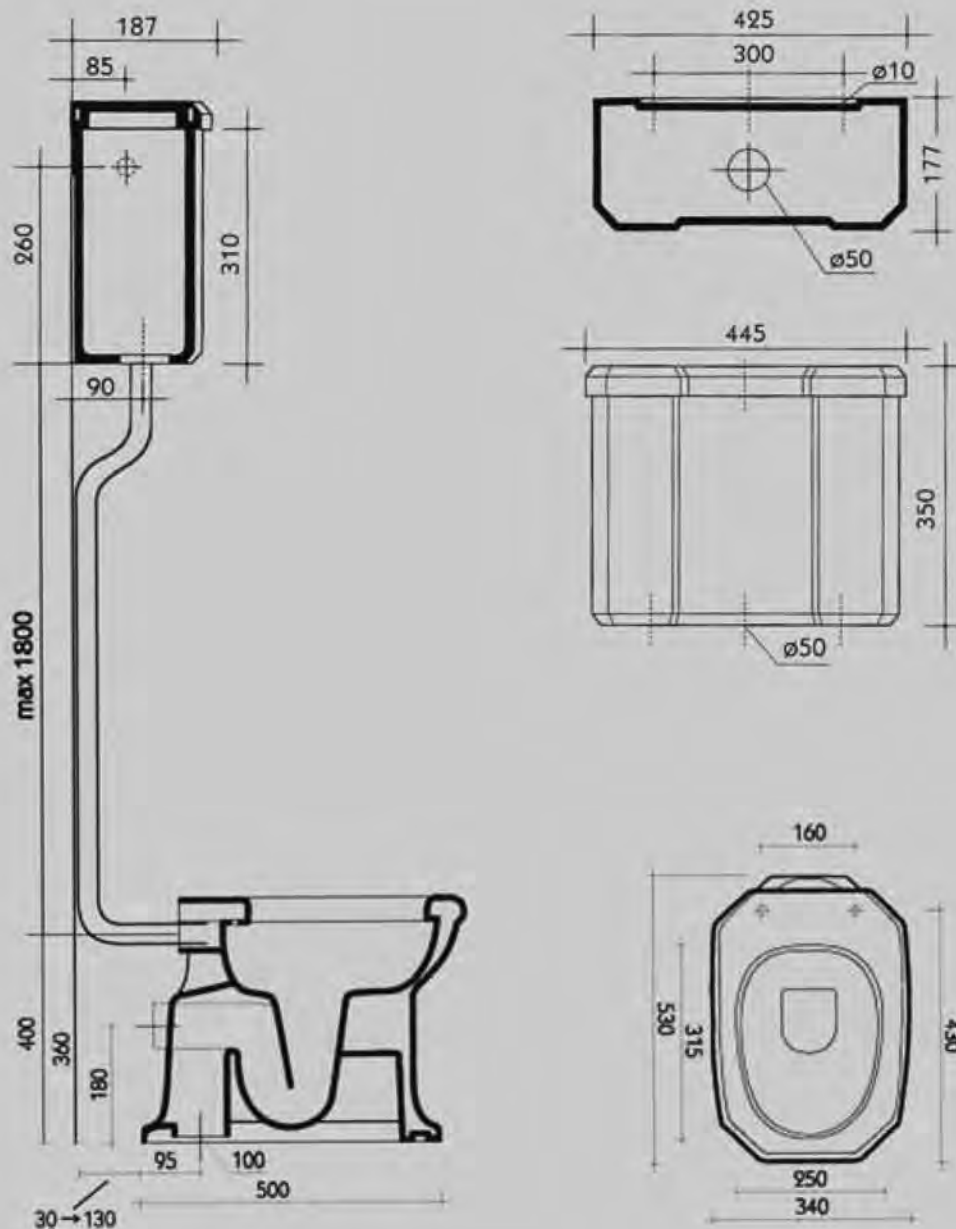

romana



art. 724

*L'evoluzione della
specie.*

*Una soluzione
che semplifica
l'installazione
e semplifica la
vita.*

*La qualità
è sempre alta.
Unica e rara.*

*The evolution
of the species.
A solution
that simplifies
installation
and will simplify
your life.*

*Quality
is also foremost.
Rare and
unique.*

Casi

art. 724

- Vaso
monoblocco S/Terra

Floor outlet
close coupled pan

art. 725

- Vaso monoblocco
P/Parete

Wall outlet
close coupled pan

art. 740

- Cassetta monoblocco

Close coupled cistern

- Sedile bianco per vaso
White seat and cover

cromo - chrome Art. 728
oro - gold Art. 729

- Sedile noce per vaso
walnut seat and cover

cromo - chrome Art. 718
oro - gold Art. 719

- Batteria monoblocco

Close coupled mechanism

cromo - chrome Art. 040.8
oro - gold Art. 040.9

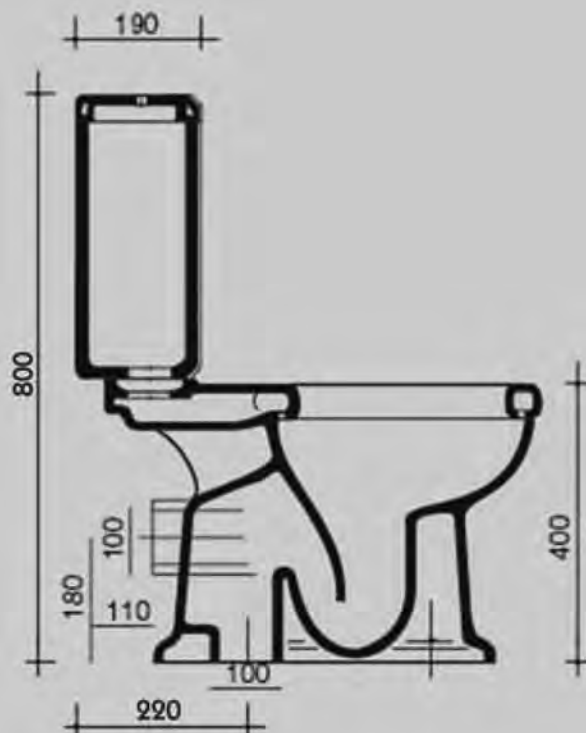
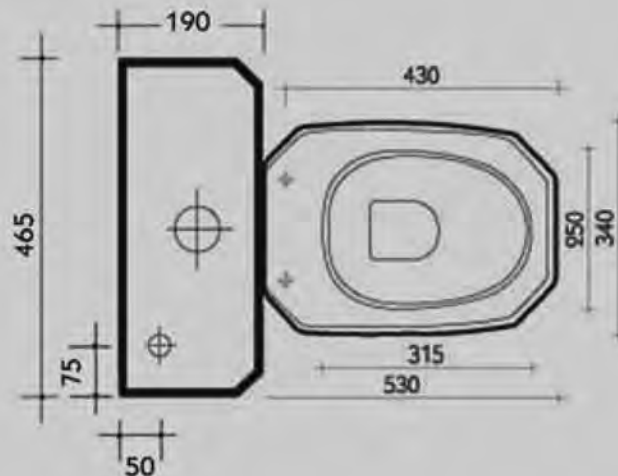

romana



art. 736

*Accanto
all'ottimizzazione
e
dell'igiene, non
manca
un pensiero
filosofico alla
base dei progetti
di questo modello:
innalzare la
mente,
staccarla da terra
e farla volare in
alto.*

*Along with
the optimization
of hygiene, there
is also
a philosophical
thought for the
basis
of the project
for this model:
elevating the
mind, separating
it from the
ground
and allowing it
to fly.*

Bidet

art. 736

- *Bidet sospeso monoforo*

Wall hung bidet monobole

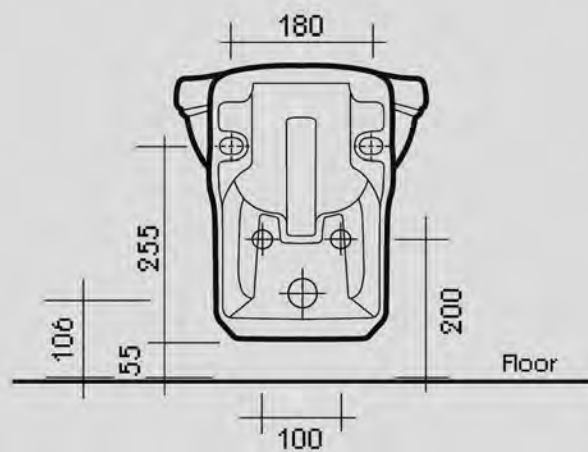
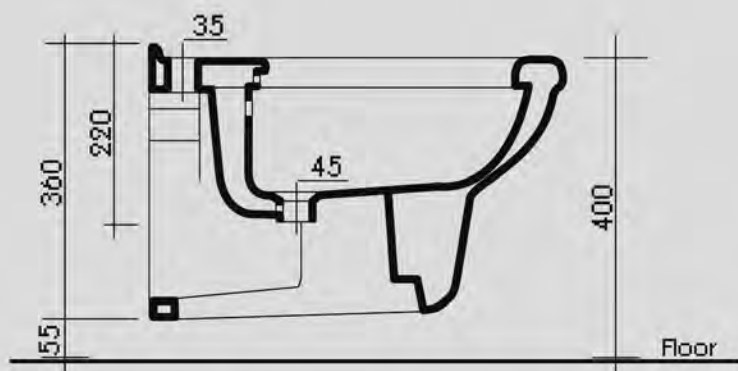
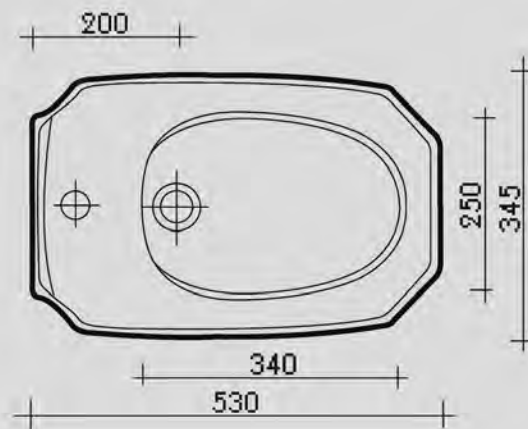

romana

art. 726

*Sospendere,
rinviando
ad altro tempo,
tutta la staticità
che blocca i
movimenti.
Lo stile di
alleggerire
un elemento,
un luogo,
una dimensione.*

*Suspending
and postponing
to other times,
the stillness that
blocks
movements.
The style of
making
lighter an
element,
a place, a
dimension.*



Casi

art. 726

- *Vaso sospeso*

Wall hung pan

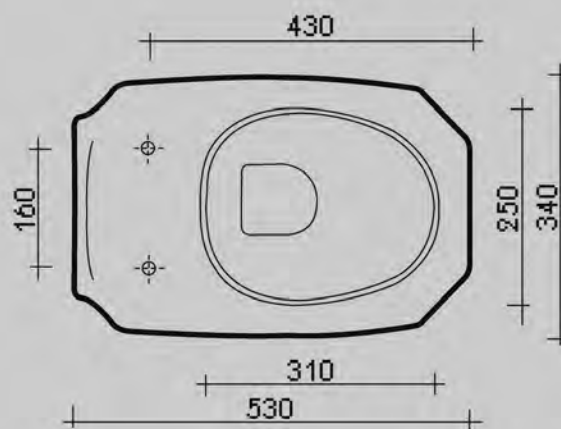

- *Sedile bianco per vaso*
White seat and cover
cromo - chrome Art. 728
oro - gold Art. 729

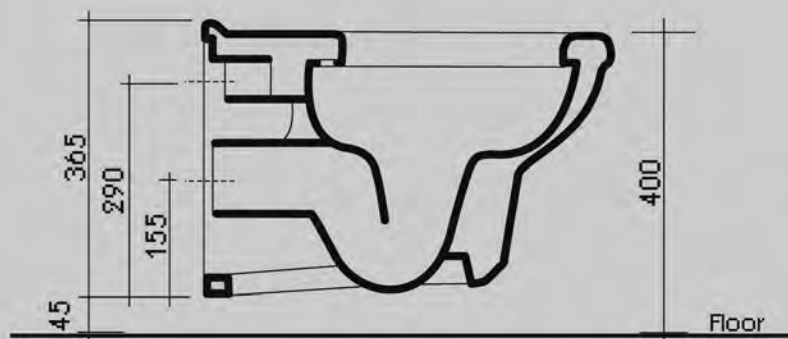

- *Sedile noce per vaso*
walnut seat and cover
cromo - chrome Art. 718
oro - gold Art. 719

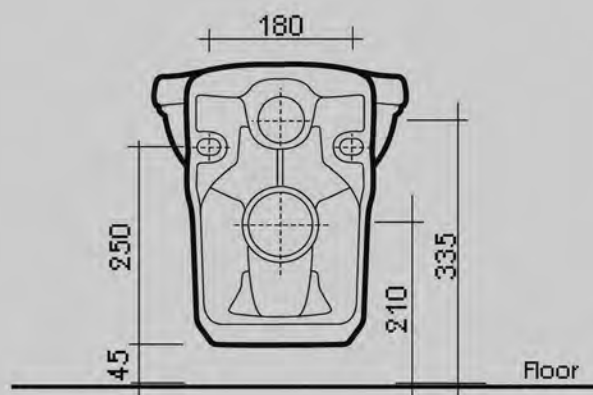

Vasche

Vasche in acrilico

Il metodo di produzione utilizzato permette di ottenere soluzioni assolutamente innovative, che conferiscono allo stesso tempo solidità strutturale e leggerezza al materiale di costruzione.

Baignoires en acrylique

La méthode de production utilisée permet d'obtenir des solutions absolument innovatives, qui confèrent de la solidité structurale ainsi que de la légèreté au matériel de construction.

Acrylic made bathtubs

Our manufacturing technique enables to achieve absolutely innovative production solutions, which grant structural strength and lightness of matter as well.

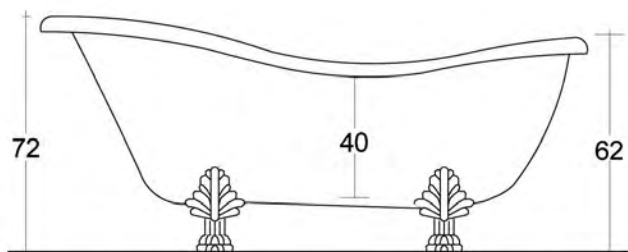
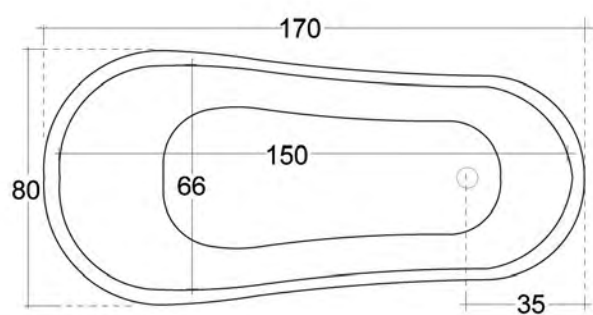

170x80xh64/72

Epoca

Questa vasca in stile rétro riproduce graziose forme d'altri tempi, posizionabile ovunque nel vostro bagno. Esterno disponibile in bianco.

Cette baignoire style rétro reproduit les formes gracieuses d'autrefois. À poser. Disponible en blanc.

Old fashioned lines mark out this gracefully shaped bathtub, which can be placed everywhere in the bathroom. Available colours white.

*“La bellezza delle cose
esiste nella mente di chi le osserva”*



Hotel Gran Duca



“Poggio Cennina”

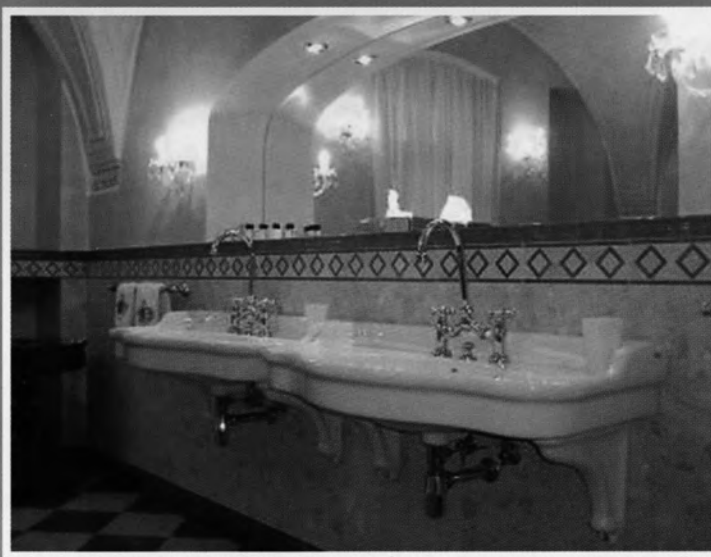

Hotel Alchymist, Praga

Alcune realizzazioni con i nostri prodotti



Classic Design Ceramics

Italian Style Bath srl

Località Quartaccio, snc 01034 Fabrica di Roma (VT) Tel. +39 0761.517230 - Fax. +39 0761.514647
www.italianstylebath.it - e.mail info@italianstylebath.it